

C-9503E Loop Isolator



Description

In loop type fire alarm system, it often occurs that partial short circuit of loop affects the whole system. C-9503E Loop Isolator can isolate the shorted circuit from the complete loop to ensure normal operation of other parts and locate the isolated part.

The isolator is applicable to all kinds of loop fire alarm systems, suitable for Class A and Class B.

Features and Benefits

- Polarity-sensitive external connections. Input and output can be used inversely without direction.
- Delayed power-up to output end devices, avoids strong transient current when the load is heavy.
- Plug-in structure.

Certificates and Compliance

- Standards: EN 54-17:2005
- Certifications: LPCB

Terminals and Installation Holes

Below figure shows terminals on the base of isolator.

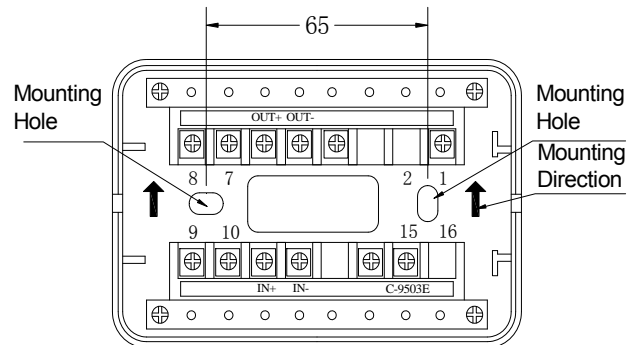

IN+, IN-: Input cable from previous device, IN+ is positive, and IN- is negative.

OUT+, OUT-: Output cable to next device. OUT+ is positive, and OUT- is negative.

Recommended Cabling

1.5mm² or above fire cable is recommended, but subject to local codes.

Application

The isolator is simply plugged onto the base after corresponding terminals are connected.

To ensure the operation of isolator and follow the EN54-17 standard, maximum 70 devices can be connected between each 2 isolators but should be subject local codes.

If the cable conduit is inside the wall, the base is installed onto the Back Box. If the cable conduit is on the surface of the wall, B-9310 Back Box is required.

The loop can be Class A or Class B mode. Below figures show the loop schematic.

Class A:

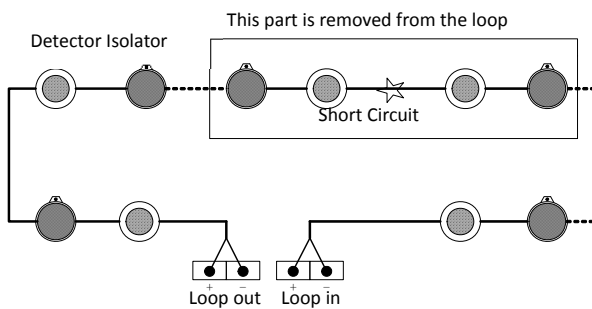

Class B:

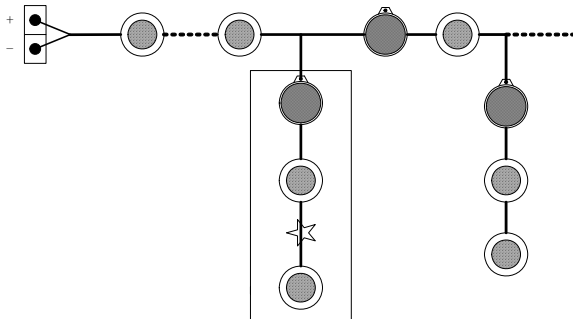

Technical Specification

Operating Voltage	24VDC
Standby Current	≤0.15mA
Capacity	Maximum 70 devices between every two isolators.
Indicator	Yellow, flashes when polling, illuminates in action.
Ingress Protection Rating	IP30
Operating Temperature	-10°C ~ +40°C
Relative Humidity	≤95%, non-condensing
Material of Enclosure	ABS
Dimension	120mm x 80mm x 39mm (with base)
Weight	About 175g (with base)

Ordering Information and Compatible Products

Part No.	C-9503E
Device Name	Loop Isolator
Order Code	1245102
Compatible Products	GST100 Intelligent Fire Panel GST200 Intelligent Fire Panel GST200-2 Intelligent Fire Panel GST200N Intelligent Fire Panel GST-IFP8 Intelligent Fire Panel
Compatible Detectors	I series intelligent detectors DI series digital detectors

Accessories and Tools



Part No.: B-9310
Device name: Back Box
Order Code: 4555575