

IIR-MNT-SLB Single L-bracket

www.boschsecurity.com



BOSCH
Invented for life



- ▶ L-mount wall bracket for single illuminator
- ▶ 180° rotation
- ▶ Fully adjustable
- ▶ Stainless steel construction

Installation/configuration notes

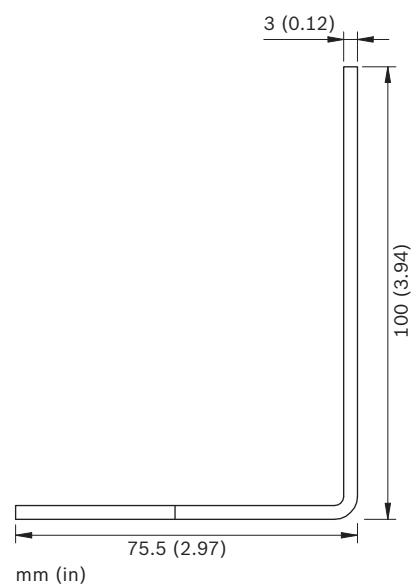
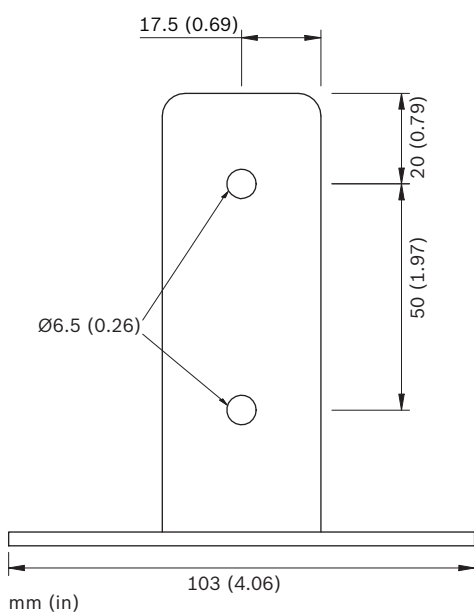

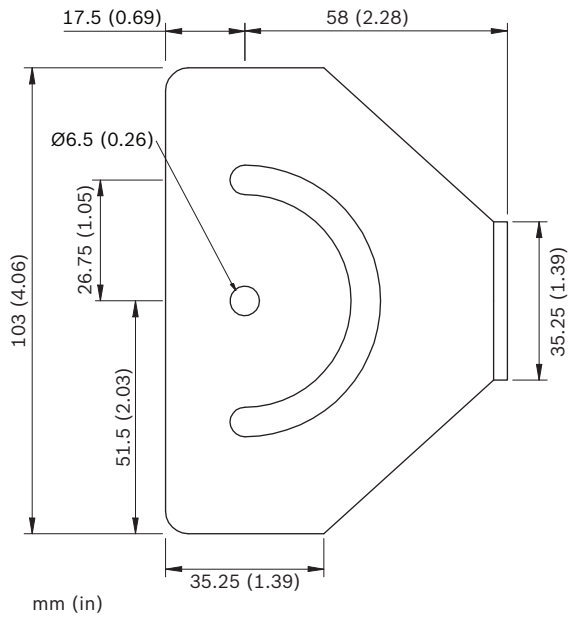

Parts included

Qty	Component
1	L-mount wall bracket for single illuminator
	Attachment components

Technical specifications

Mechanical	
Dimensions (W x H x D)	103 x 100 x 75.5 mm (4.06 x 3.94 x 2.97 in)
Material	Stainless steel
Finish	Black power coating
Weight	225 g (0.5 lbs)

Ordering information

IIR-MNT-SLB Single L-bracket
 Illuminator single L-bracket, black
 Order number **IIR-MNT-SLB**

Represented by:

Europe, Middle East, Africa:
 Bosch Security Systems B.V.
 P.O. Box 80002
 5600 JB Eindhoven, The Netherlands
 Phone: + 31 40 2577 284
 emea.securitysystems@bosch.com
 emea.boschsecurity.com

North America:
 Bosch Security Systems, Inc.
 130 Perinton Parkway
 Fairport, New York, 14450, USA
 Phone: +1 800 289 0096
 Fax: +1 585 223 9180
 onlinehelp@us.bosch.com
 www.boschsecurity.us

Asia-Pacific:
 Robert Bosch (SEA) Pte Ltd, Security Systems
 11 Bishan Street 21
 Singapore 573943
 Phone: +65 6571 2808
 Fax: +65 6571 2699
 apr.securitysystems@bosch.com
 www.boschsecurity.asia