

- ✓ BACnet
- ✓ CEA-709
- ✓ KNX
- ✓ Modbus
- ✓ M-Bus
- ✓ OPC

Datasheet #89035818

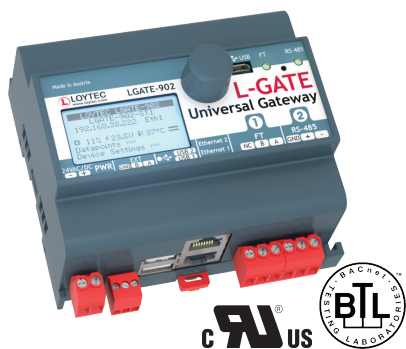

The LGATE-902 Gateway is a powerful gateway that can host user specific graphical pages. The gateways provide connectivity functions to concurrently integrate CEA-709 (LonMark Systems), BACnet, KNX, Modbus, and M-Bus. Local operation and override is provided by the built-in jog dial and the backlit display (128x64 pixels). Device and data point information is provided by the web interface and shown on the display via symbols and in text format.

LonMark Systems can be integrated via IP-852 (Ethernet/IP) or TP/FT-10. LGATE-902 features an integrated Remote Network Interface (RNI) to access the TP/FT-10 channel on the device via Ethernet/IP. BACnet integration is supported through BACnet/IP (Ethernet/IP) or BACnet MS/TP (RS-485). LGATE-902 ist BACnet Building Controller (B-BC) BTL certified and can be configured to be a BBMD.

In addition, the gateway provides connectivity to KNXnet/IP and Modbus (RTU, TCP, Master or Slave). M-Bus and KNX TP1 device integration needs optional interface modules.

Through the built-in web server, all data points can be monitored and changed. The gateway functionality allows data communication between all communication technologies available on the device. Different technology data points are mapped through Local Connections on the device. The mapping of different technology data points on distributed devices is supported by Global Connections. The gateway also support Smart Auto-Connect™ – the automatic generation of connections to substantially reduce engineering efforts and cost. Math objects allow to execute mathematical operations on data points. All technology data points are automatically created as OPC XML-DA and OPC UA data points.

The LGATE-902 Gateway is equipped with two Ethernet ports. It can either be configured to use the internal switch to interconnect the two ports or every port is configured to work in a separate IP network.

When the Ethernet ports are configured for two separate IP networks, one port can be connected for instance to a WAN (Wide Area Network) with enabled network security (HTTPS) while the second port can be configured to be connected to an insecure network (LAN) where the standard building automation protocols like BACnet/IP, LON/IP, or Modbus TCP are present. These devices also feature fire-wall functionality of course to isolate particular protocols or services between the ports.

Using the internal switch, a daisy chained line topology of up to 20 devices can be built, which reduces costs for network installation. The IP switch also allows the setup of a redundant Ethernet installation (ring topology), which increases reliability. The redundant Ethernet topology is enabled by the Rapid Spanning Tree Protocol (RSTP), which is supported by most managed switches.

The L-GATE devices provide fully featured AST™ functionality (Alarming, Scheduling, and Trending) and can be integrated perfectly into the L-WEB System.

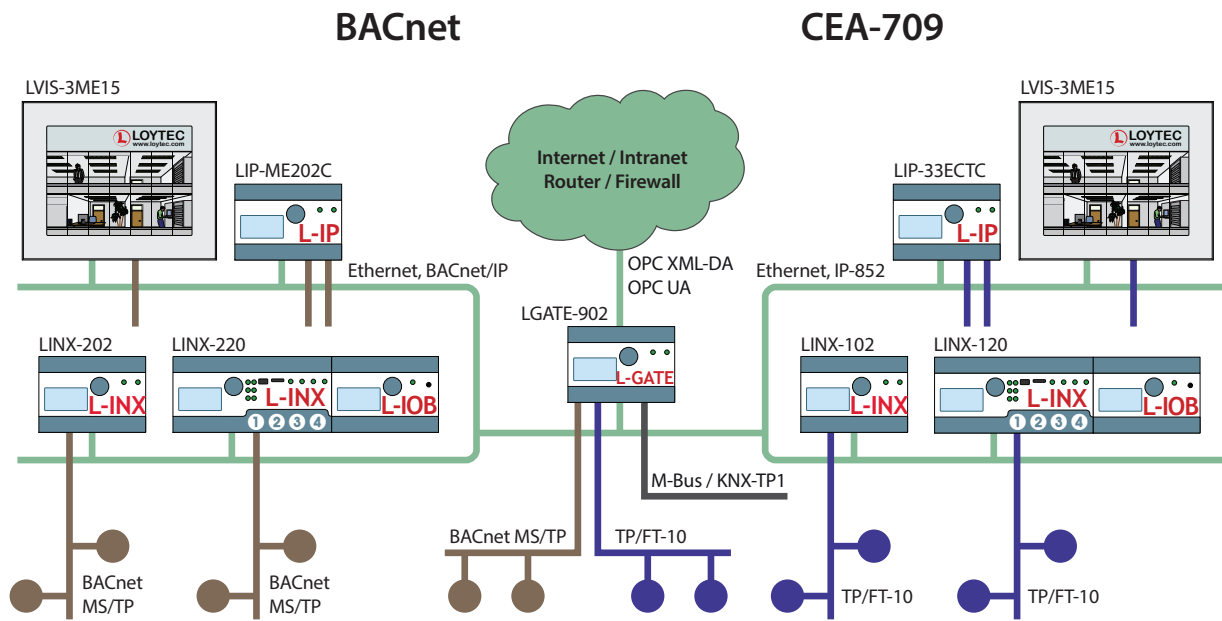

Features

- Universal Gateway for BACnet, LonMark, KNX, Modbus, M-Bus, and EnOcean
- Compliant with ANSI/ASHRAE 135-2012 and ISO 16484-5:2012 standard
- B-BC (BACnet Building Controller) functionality, BTL certified
- Supports BBMD (BACnet Broadcast Management Device)
- Supports BACnet MS/TP or BACnet/IP
- BACnet Client Function (Write Property, Read Property, COV Subscription)
- BACnet Client Configuration with configuration tool (scan and EDE import)
- Compliant with CEA-709, CEA-852, and ISO/IEC 14908 Standard (LonMark System)
- Supports TP/FT-10 or IP-852 (Ethernet/IP)
- Support of dynamically created or static NVs
- Support of user-defined NVs (UNVTs) and Configuration Properties (SCPTs, UCPTs)
- Remote Network Interface (RNI) with 2 MNI devices
- Direct connection to KNX/IP, KNX TP1 connection via LKNX-300 Interface
- M-Bus Master according to EN 13757-3, connection via M-Bus Level Converter (LMBUS-20 or LMBUS-80)
- Modbus TCP and Modbus RTU (Master or Slave)
- Automatic creation of Local Connections (Smart Auto-Connect™)
- Math objects to execute mathematical operations on data points
- Automatic mapping of network variables to BACnet objects in accordance with CEN/TS 15231:2005
- Alarming, Scheduling, and Trending (AST™)
- Event-driven e-mail notification
- Stores customized graphical pages
- Visualization of customized graphical pages through LWEB-900 and LWEB-802/803
- Built-in OPC XML-DA and OPC UA server
- Dual switched or separated Ethernet ports
- Access to network statistics
- Integrated web server for device configuration and monitoring data points
- Manual operation using the jog dial or VNC client
- Local and remote access to information about device status and data points
- 128x64 graphic display with backlight
- Configurable via Ethernet/IP or TP/FT-10
- Connection to EnOcean wireless devices via LENO-80x Interface
- Supports SMI (Standard Motor Interface) through LSMI-80x
- Supports WLAN through LWLAN-800 Interface
- Stores user-defined project documentation

Specifications			
Dimensions (mm)	107 x 100 x 75 (L x W x H), DIM045		
Installation	DIN rail mounting following DIN 43880, top hat rail EN 50022		
Power supply	12 – 35 VDC / 12 – 24 VAC ±10 %, typ. 2.5 W		
Operating conditions	0 °C to 50 °C, 10 – 90 % RH @ 50 °C, non condensing, degree of protection: IP40, IP20 (terminals)		
Interfaces	<table border="0"> <tr> <td style="vertical-align: top;"> 2 x Ethernet (100Base-T): OPC XML-DA, OPC UA, LonMark IP-852**, BACnet/IP*, KNXnet/IP, Modbus TCP (Master or Slave), HTTP, FTP, SSH, HTTPS, Firewall, SNMP 2 x USB-A: WLAN (needs LWLAN-800), EnOcean (needs LENO-80x) SMI (needs LSMI-804) </td> <td style="vertical-align: top; padding-left: 20px;"> 1 x TP/FT-10** (LonMark system) 1 x RS-485 (ANSI TIA/EIA-485): BACnet MS/TP* or Modbus RTU (Master or Slave) 1 x EXT: M-Bus, Master EN 13757-3 (needs L-MBUS20/80) or KNX TP1 (needs LKNX-300) or SMI (needs LSMI-800) </td> </tr> </table> <p>* Either BACnet/IP or BACnet MS/TP ** Either LonMark IP-852 or TP/FT-10</p>	2 x Ethernet (100Base-T): OPC XML-DA, OPC UA, LonMark IP-852**, BACnet/IP*, KNXnet/IP, Modbus TCP (Master or Slave), HTTP, FTP, SSH, HTTPS, Firewall, SNMP 2 x USB-A: WLAN (needs LWLAN-800), EnOcean (needs LENO-80x) SMI (needs LSMI-804)	1 x TP/FT-10** (LonMark system) 1 x RS-485 (ANSI TIA/EIA-485): BACnet MS/TP* or Modbus RTU (Master or Slave) 1 x EXT: M-Bus, Master EN 13757-3 (needs L-MBUS20/80) or KNX TP1 (needs LKNX-300) or SMI (needs LSMI-800)
2 x Ethernet (100Base-T): OPC XML-DA, OPC UA, LonMark IP-852**, BACnet/IP*, KNXnet/IP, Modbus TCP (Master or Slave), HTTP, FTP, SSH, HTTPS, Firewall, SNMP 2 x USB-A: WLAN (needs LWLAN-800), EnOcean (needs LENO-80x) SMI (needs LSMI-804)	1 x TP/FT-10** (LonMark system) 1 x RS-485 (ANSI TIA/EIA-485): BACnet MS/TP* or Modbus RTU (Master or Slave) 1 x EXT: M-Bus, Master EN 13757-3 (needs L-MBUS20/80) or KNX TP1 (needs LKNX-300) or SMI (needs LSMI-800)		
Tools	L-INX Configurator		
Remote Network Interface	1 RNI with 2 MNI devices		

Resource limits

Total number of data points	10 000	LonMark Schedulers	100
OPC data points	2 000	LonMark Alarm Servers	1
BACnet objects	750 (analog, binary, multi-state)	E-mail templates	100
BACnet client mappings	750	Math objects	100
BACnet calendar objects	25	Alarm logs	10
BACnet scheduler objects	100 (64 data points per object)	M-Bus data points	250
BACnet notification classes	32	Modbus data points	250
Trendlogs (BACnet or generic)	256 (4 000 000 entries, ~ 60 MB)	KNX TP1 data points	250
Total trended data points	256	KNXnet/IP data points	250
CEA-709 network variables (NVs)	1 000	Connections (Local / Global)	1 000 / 250
CEA-709 Alias NVs	1 000	Number of L-WEB clients	32 (simultaneously)
CEA-709 External NVs (polling)	1 000	Number of EnOcean devices	25
CEA-709 address table entries	512 (non-ECS mode: 15)	EnOcean data points	250
LonMark Calendars	1 (25 calendar patterns)	SMI devices (per channel)	16

Order Number	Product Description
LGATE-902	Universal Gateway
LPOW-2415A	LIOB-Connect power supply unit, 24 VDC, 15 W
LPOW-2415B	Power supply unit with power connector 24 VDC, 15 W
L-MBUS20	M-Bus level converter for 20 M-Bus devices
L-MBUS80	M-Bus level converter for 80 M-Bus devices
LKNX-300	KNX interface to connect KNX TP1 devices
LENO-800	EnOcean Interface 868 MHz Europe
LENO-801	EnOcean Interface 902 MHz USA/Canada
LENO-802	EnOcean Interface 928 MHz Japan
LWLAN-800	Wireless LAN Interface IEEE 802.11bgn
LSMI-800	Standard Motor Interface for 16 motors via EXT port
LSMI-804	Standard Motor Interface for 64 motors, 4 SMI channels via USB